

WORKHORSE™ Professional Grade

PGI 28-48 REVERSE OSMOSIS SYSTEM

- ◆ Pre-engineered for Maximum Versatility in a Standard Product Line
- ◆ Optional Dual RO Alternator with demand based simultaneous operation
- ◆ Variable Voltage 208v/240v/480v/575v, 3 Phase
- ◆ Adjustable Recovery 50-75%
- ◆ Optional Integrated Pretreatment Injection Configurations:
 - Chlorine Destruct/Antiscalant
 - Optional Integrated Clean in Place System
- ◆ Automatic Membrane Feed Flush on Start
- ◆ Programmable Auto-flush
- ◆ High Conductivity Product Divert
- ◆ Membrane Isolation Sample Ports
- ◆ Tank Full High/ Tank Full Low/Low Level Float Inputs
- ◆ Powder-coated Aluminum Frame, Brass Free Design

DESIGN PARAMETERS

MODEL	PGI 28	PGI 38	PGI 48
PERFORMANCE			
Nominal Rejection	99%	99%	99%
Production (GPD)*	23,080	34,500	46,000
Product Flow (GPM)*	16	24	32
Recovery	50-75% Adjustable		
ELECTRICAL			
Three Phase	208-230V/440-480 (Check label)		
Horsepower/AMPS	7.347 HP // 20.4-19.8/9.95-9.85 Amps		
MEMBRANES			
Size (in)	8" X 40"	8" X 40"	8" X 40"
Quantity	2	3	4
Type	THIN FILM NANOCOMPOSITE (TFN)		
FEED WATER REQUIREMENTS			
Chlorine Tolerance	<0.1 PPM		
Temperature	Maximum 133° F (45 °C)		
Operating pH Range	2-10		
Cleaning pH	1-12		
Pre-Filtration	5 micron		
Pressure Range (PSIG)	120-160		
Max. Fouling Index (SDI)	<5.0		
DIMENSIONAL DATA			
Connections	Inlet 1 ½" FIP, Outlet 1" QC, Drain 1" QC		
H x W x D	80" X 62" X 38"		
OPERATING WEIGHT LBS			
977 lbs			



NuStream™
filtration



Intertek
5012025

Conforms to
UL Std. 979

Certified to
CSA Std.
C22.2#14



*Product flow rate varies with temperature, all models are rated at 77°F (25° C) with feed water of 1500 ppm NaCl Solution @ 150 psi applied pressure. Permeate flow for individual elements may vary + or - 15%.

WORKHORSE™ Professional Grade

PGI 28-48 REVERSE OSMOSIS SYSTEM

FLOW SCHEMATIC

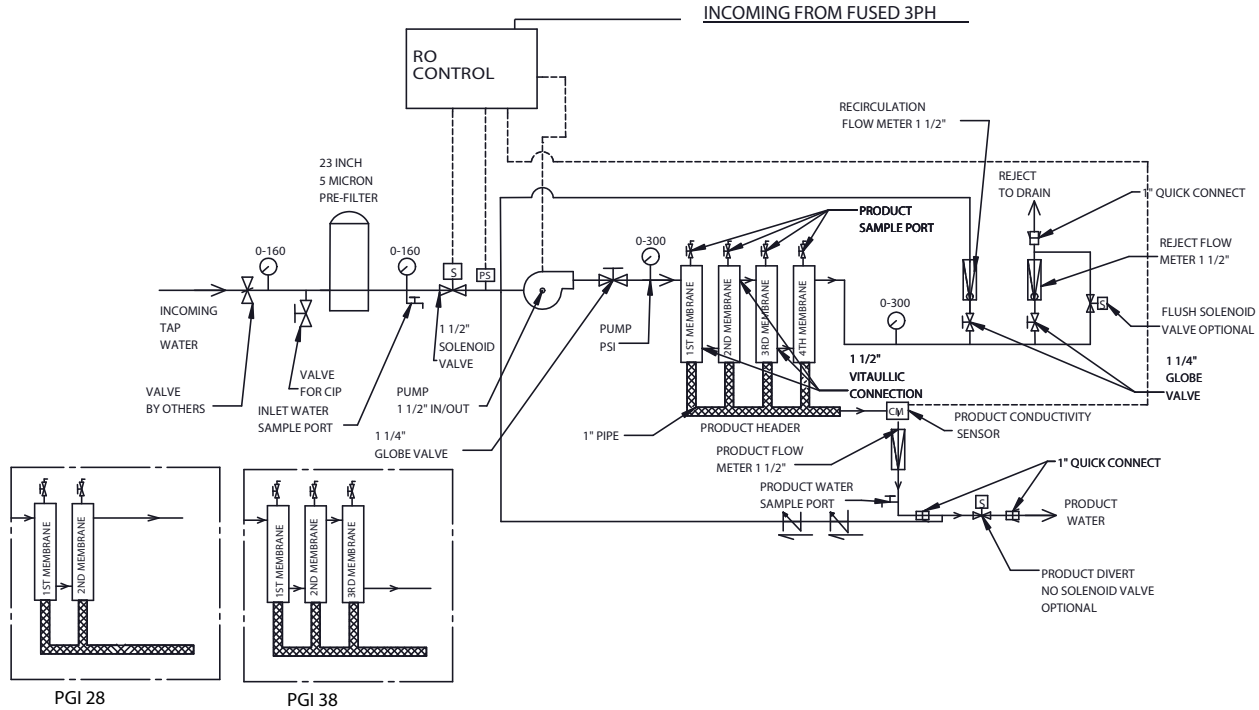

Temperature	Product Flow GPM/ GPD		
	77 F (25) C	62 F (17) C	50 F (10) C
Model			
PG 24	3.4/ 5,000	2.7/ 3,950	2.1/ 3,150
PG 34	5.2/ 7,500	4.1/ 5,925	3.2/ 4,725
PG 44	6.9/ 10,000	5.4/ 7,900	4.3/ 6,300
PG 54	8.6/ 12,500	6.8/ 9,875	5.4/ 7,785
PG 64	10.4/ 15,000	8.2/ 11,850	6.5/ 9,450
PG 74	12.1/ 17,500	9.6/ 13,825	7.6/ 11,025
PG 84	13.8/ 20,000	10.9/ 15,800	8.7/ 12,600
PGI 28	16/23,000	12.5/ 17,900	10.8/ 14,500
PGI 38	24/ 34,500	19/ 27,373	15.1/ 21,829
PGI 48	32/ 46,000	25.3/ 36,498	20.2/ 29,106

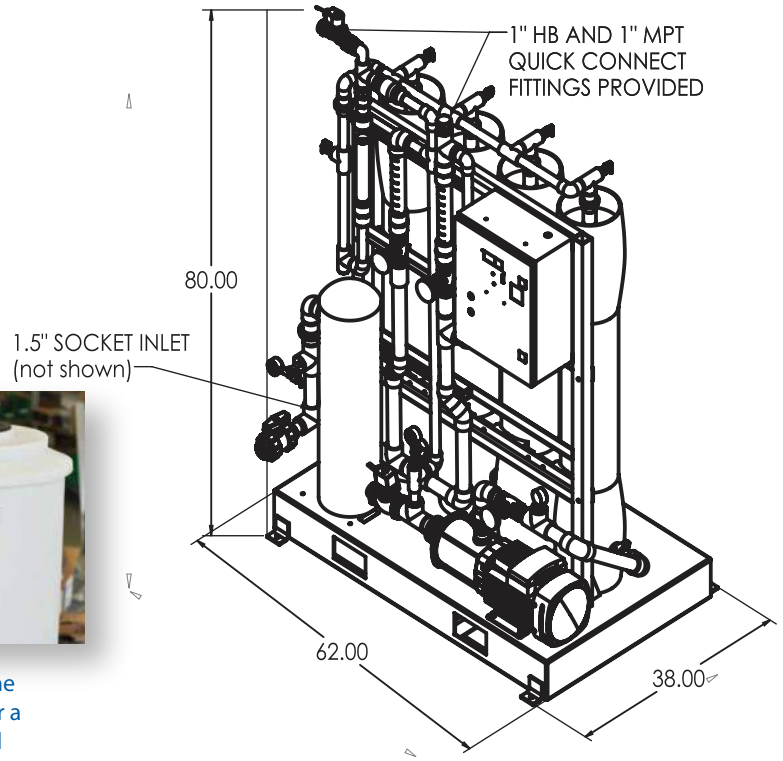

NuStream™
filtration



60 Gallon antiscalent and chlorine destruct chem injection tanks for a smaller footprint than traditional carbon/softener configuration.