











PG54-PG84 REVERSE OSMOSIS SYSTEM

-  Pre-engineered for maximum versatility in a standard product line
-  Expandable Configuration
-  Variable Voltage 208v/240v/480v/575v , 3Phase
-  Adjustable Recovery 50-75%
-  Optional Integrated Pretreatment Injection Configurations:
 - Chlorine Destruct/Antiscalent
 - Optional Integrated Clean In Place System
-  Automatic Membrane Feed Flush On Start
-  Programmable Auto-flush
-  Product Divert Option
-  Membrane Isolation Test Ports
-  Tank Full High/ Tank Full Low/Low Level Float Inputs

DESIGN PARAMETERS

MODEL	PG 54	PG 64	PG 74	PG 84
PERFORMANCE				
Nominal Rejection	99%	99%	99%	99%
Production (GPD)*	1000	12000	14000	16000
Product Flow (GPM)*	6.9	8.3	9.3	11.1
Recovery	50-75% Adjustable			
ELECTRICAL				
Three Phase	208-230V/440-480 (Check label)			
Horsepower/AMPS	7.347 HP //20.4-19.8/9.95-9.85 Amps			
MEMBRANES				
Size (in)	4" X 40"	4" X 40"	4" X 40"	4" X 40"
Quantity	5	6	7	4
Type	Spiral Composite Polyimide (TFC)			
FEED WATER REQUIREMENTS				
Chlorine Tolerance	<0.1 PPM			
Temperature	Maximum 133° F (45 °C)			
Operating pH Range	2-10			
Cleaning pH	1-12			
Pre-Filtration	5 micron			
Pressure Range (PSIG)	120-160			
Max. Fouling Index (SDI)	<5.0			
DIMENSIONAL DATA				
Connections	Inlet 1" FIP, Outlet 1" QC, Drain 1" QC			
H x W x D	73" X 33" X 42"			



PG54-PG84 REVERSE OSMOSIS SYSTEM

FLOW SCHEMATIC

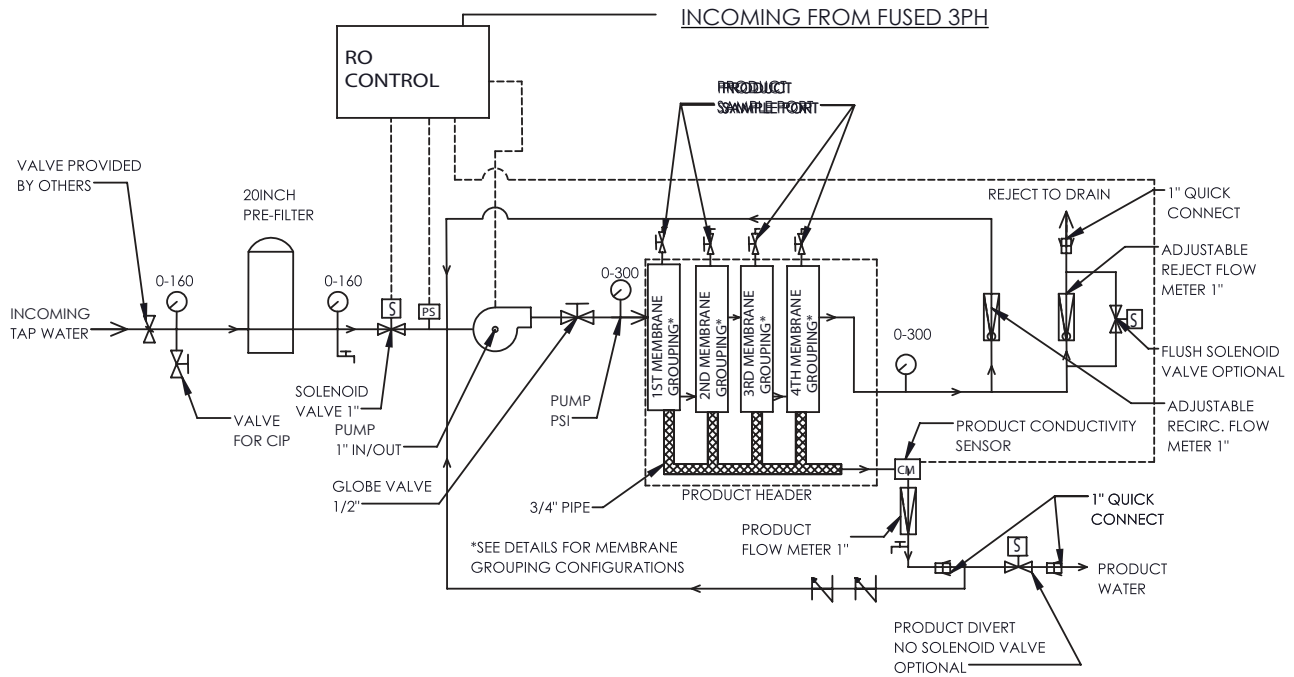

1" HB and 1" MPT QUICK CONNECT FITTINGS PROVIDED

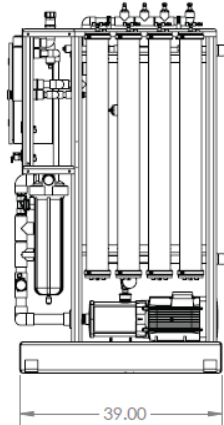
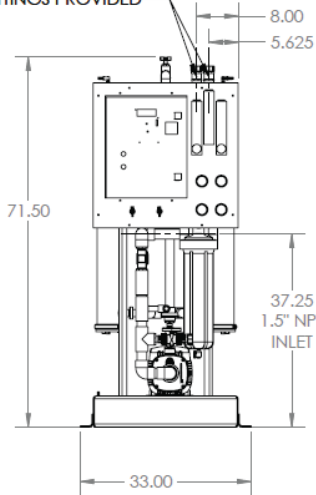

Configuration	Multistage/Single Pass
Inlet Requirements	25 PSI
Feed Water Temp	50-80 F
Source	City/Well/Softened
Prefiltration	5 Micron Nominal
SDI	<3
System Recovery	50-75%
Salt Rejection	99%
Product Flow	11.1 GPM
Basis	77F pH 6.5-8
Operating Dimensions	73" x 33" x 42" (H x W x D)



NuStream™
filtration



Membrane test ports for isolation profiling